

# 58529A

## Line Amplifier with L1 Bandpass Filter

### Information Note

# Information Note

This information note describes the 58529A Line Amplifier with L1 Bandpass Filter accessory.

The accessory is a broadband amplifier integrated with an L1 bandpass filter designed to overcome cable loss and protect the GPS receiver from out-of-band noise and interference.

For assistance, contact:

Symmetricom, Inc.  
2300 Orchard Parkway  
San Jose, CA 95131-1017

U.S.A. Call Center:  
888-367-7966 (from inside U.S.A. only – toll free)  
408-428-7907

U.K. Call Center:  
+44.7000.111666 (Technical Assistance)  
+44.7000.111888 (Sales)

Fax: 408-428-7998

E-mail: [ctac@symmetricom.com](mailto:ctac@symmetricom.com)

Internet: <http://www.symmetricom.com>

## Warning Symbols Used In This Note



Instruction manual symbol; the product will be marked with this symbol when it is necessary for the user to refer to the instruction manual.



Indicates hazardous voltages.



Indicates earth (ground) terminal.



or



Indicates terminal is connected to chassis when such connection is not apparent.



Indicates Alternating current.



Indicates Direct current.

# Information Note

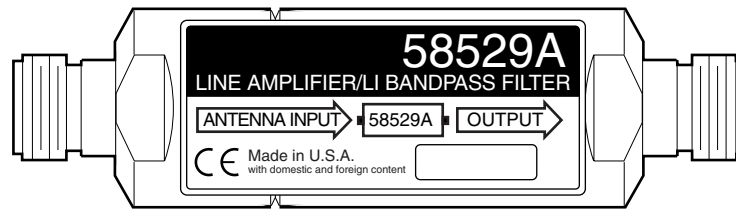

Figure 1. 58529A Line Amplifier with L1 Bandpass Filter

## 1.0 Introduction

The 58529A Line Amplifier with L1 Bandpass Filter is one component of a complete line of GPS accessories available from Symmetricom. These accessories are designed to deliver precise GPS signals over a wide temperature range and in harsh environmental conditions.

## 2.0 Description

The 58529A Line Amplifier with L1 Bandpass Filter is a broadband amplifier integrated with an L1 bandpass filter designed to overcome cable loss and protect the GPS receiver from out-of-band noise and interference.

The amplifier provides > 20 dB of gain (+25 dB typical) and receives power from the GPS receiver through the antenna cable.

The filter features narrow bandwidth and steep roll-off. It insures accurate satellite tracking and signal reception even in the presence of electromagnetic disturbances.

The key features of the amplifier and filter include:

- High gain and low noise figure.
- High isolation from input to output.
- Low insertion loss.
- Weather-resistant construction for use outdoors.

**Note:** If two amplifiers are required, they can be connected in series without signal saturation. See “Amplifier Recommendations” below for more information about the need for amplifiers.

## 3.0 Installation

It is recommended that the line amplifier be placed as close to the antenna as possible. The best location is inside the mounting mast as shown in Figure 3. The 58529A is shaped so it will fit easily inside a mounting mast; otherwise place the amplifier within 10 meters of the antenna in order to minimize the possibility of noise entering the system before signal amplification. Mount the line amplifier so it will not be immersed in, or exposed to, standing water.

This Information Note describes how to install the amplifier inside the mounting mast, how to mount the amplifier on a surface or a pole using a mounting plate, and how to weatherproof connections for exposed outdoor installations.

**Note:** When installing any electrical device always follow the rules prescribed by your local electrical and building ordinances.

### **Amplifier Recommendations**

This section provides information that will help you determine how many amplifiers may be needed for your installation. In general, an amplifier is required if there is more than 20 dB of cable loss between the GPS antenna and the GPS receiver. Two amplifiers are recommended when there is more than 40 dB of cable loss.

#### **For cable:**

The need for amplifiers can be estimated using the following guidelines:

- If your installation involves less than 20 dB of cable loss, an amplifier is not required.
- If there is from 20 to 39 dB of cable loss, one amplifier will provide sufficient gain to ensure proper operation.
- If there is from 40 to 59 dB of cable loss, two amplifiers are recommended for proper operation. This is the maximum cable loss for which the GPS receiver can provide power. If you have calculated more than 60 dB of cable loss for your installation, then a lower-loss cable must be used. The lowest-loss standard cable is LMR 400 (58520A or 58521A) with a loss of 5 dB per 30.5 meters (100 ft).

**Note:** These guidelines include a safety margin to account for any degrading of signal strength due to temperature changes in the cable, variation of sensitivity in the antenna and receiver, and minor errors made in estimating cable loss.

### Tools Required

- Scissors or knife to cut the shrink tubing if needed.
- A heat gun or equivalent heating source to shrink the tubing.
- Small to medium size adjustable wrench.
- Small Phillips screwdriver and 4 mm hex wrench (for antenna assembly).

### Dimensions of Line Amplifier with L1 Filter

Figure 2 shows the major dimensions of the line amplifier with filter.

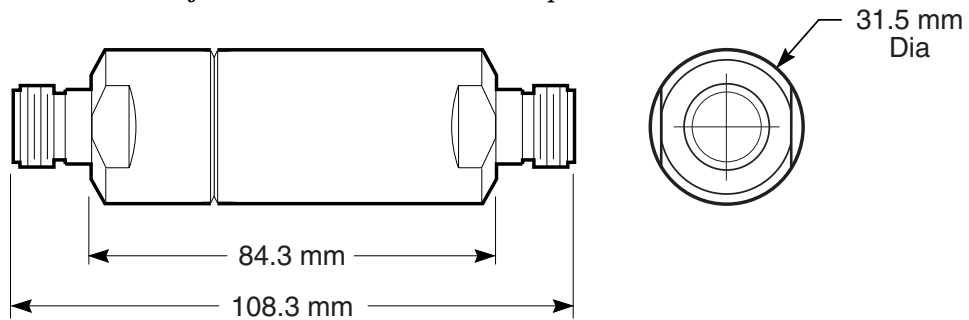

**Figure 2. 58529A Line Amplifier with L1 Bandpass Filter**

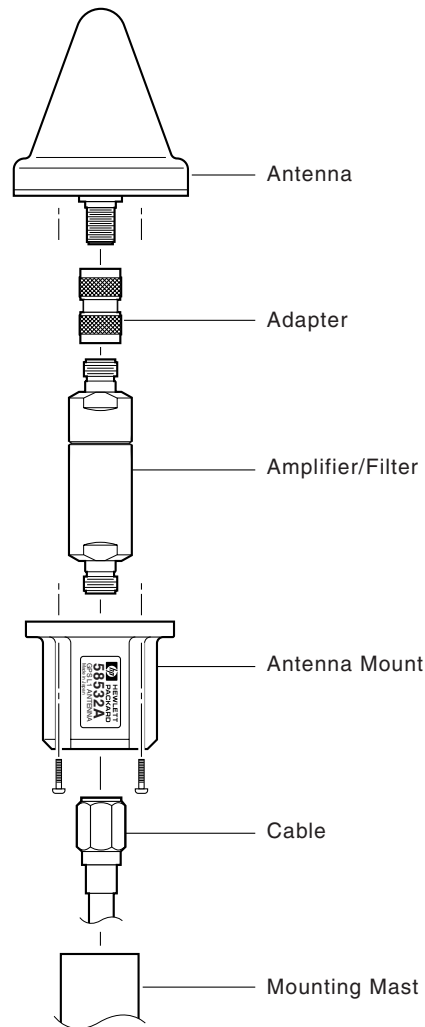

**Figure 3. Antenna to Amplifier Assembly Drawing**

**4.0 Antenna to Amplifier Assembly Procedure** (Refer to Figure 3 while following this procedure.)

1. Attach a Type-N plug to Type-N plug adapter to the antenna and tighten.
2. Attach the adapter to the antenna input of the line amplifier and tighten.

**Note:** Although the supplied shrink tubing can be used to protect the connections from moisture, when the amplifier is mounted inside a mast the shrink tubing is not necessary. Refer to Section 8.0 for more information about protecting outdoor connections.

3. Lower the antenna/amplifier assembly through the antenna mount.
4. Attach the antenna to the antenna mount by tightening the four pan head screws into the antenna using a Phillips screwdriver. Do not over-tighten.

**Note:** The gasket creates a very tight seal between the antenna and the antenna mount. Consequently, extra pressure may be required to disassemble the antenna from the antenna mount. Carefully use a flat-blade screwdriver as a wedge when disassembly is required.

5. Route the cable through the mast.
6. Attach the cable to the amplifier output connector and tighten.

7. Attach the antenna/amplifier assembly to the mast by sliding the assembly over the mast until the mounting base rests against the top of the mast. Tighten the two set screws (4 mm) in the mount against the mast so the antenna/amplifier assembly is securely held in place on the mast.
8. Secure the cable to a fixed object where it exits the mast to take the weight of the cable off the cable-to-amplifier connection.

## 5.0 Mounting Plate and Brace (Option AUB)

Refer to Figure 4. A mounting plate and brace (1 & 2) are available for the 58529A line amplifier (3). Four screws (4) attach the brace around the amplifier to the mounting plate. For ordering information, see “Parts Required,” above.

The mounting plate provides two oblong shaped-slots for mounting the amplifier to a pole or surface. These slots are 7.9 mm (5/16 in) by 15.87 mm (5/8 in).

### Attaching the Amplifier to the Mounting Plate using the Brace

The mounting plate has four countersunk screw holes on one side. The screws will be inserted from this side of the plate.

1. Position the brace on the mounting plate. Align the threaded holes in the brace over the four holes in the mounting plate.
2. Insert the four screws and turn the screws enough to attach the brace loosely to the mounting plate.
3. Slide the line amplifier under the brace and position so that the label is visible through the opening in the brace.
4. Tighten the screws and verify that the line amplifier is held securely in place.

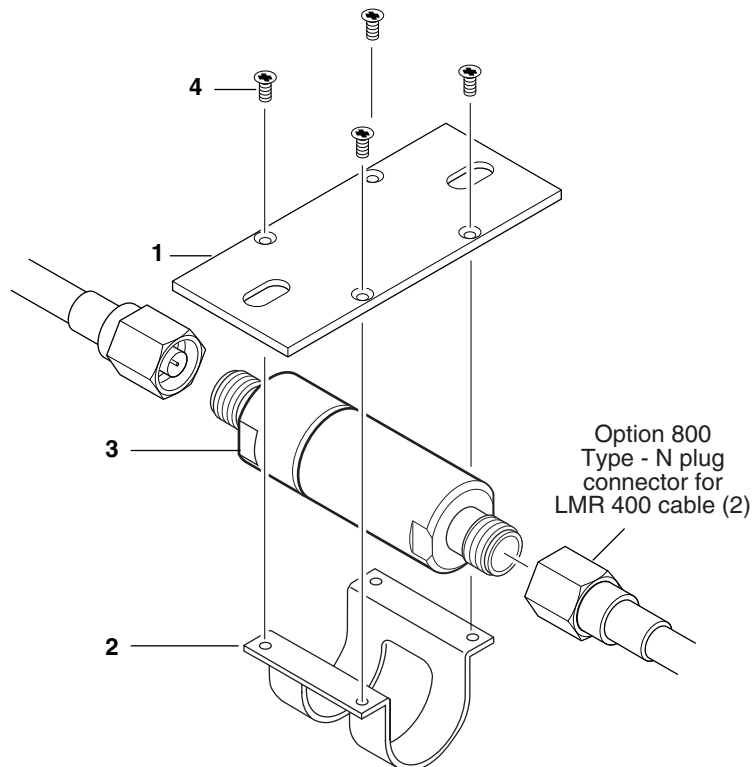
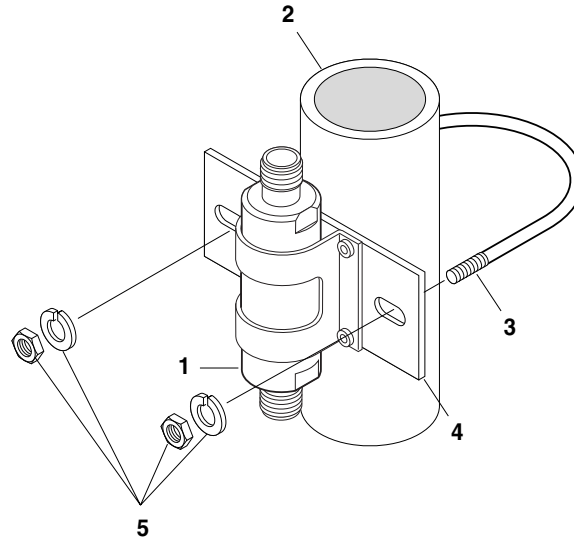

**Figure 4. Line Amplifier and Mounting Plate with Brace**

## 6.0 Mounting to a Pole

Refer to Figure 5. To mount the amplifier (1) on a pole (2), place the U-bolt (3), (customer-supplied) around the pole and slide the ends of the U-bolt through the oblong slots in the mounting plate (4). Place lock washers and nuts supplied with the U-bolt (5) over each threaded end of the U-bolt and tighten the nuts down securely.

**Caution:** To avoid deforming the mounting plate, tighten the nuts firmly but do not overtighten.



**Figure 5. Pole Mounting the Line Amplifier**

**Caution:** If you mount the line amplifier to the antenna mast, you will have to bring the antenna cable from the bottom of the mast up to where the line amplifier is located. In addition to weatherproofing the connections, make sure you have enough antenna cable to form a drip loop where the cable exits from the bottom of the mast.

- **Required Parts:**

- Mounting plate, brace, and 4 screws (Option AUB or ordered separately).
- U-bolt - 76.2 mm (3 in), with lock washers and nuts (customer-supplied).

**Note:** Protecting outdoor connections is recommended. Refer to Section 8.0 for more information.

## 7.0 Mounting to a Surface

The amplifier assembly can be mounted to any wood or masonry surface. Refer to Figure 6.

For wood mounting, drill two holes approximately 76.2 mm (3 in) apart. Fasten the amplifier assembly (1 & 2) to the surface using fasteners (3) no more than 6.35 mm (1/4 in) in diameter.

For masonry mounting, drill two holes approx. 76.2 mm (3 in) apart, using a masonry drill. The diameter of the holes will depend on the diameter of the masonry anchors you use. Select anchors that accept fasteners no larger than 6.35 mm (1/4 in) in diameter.

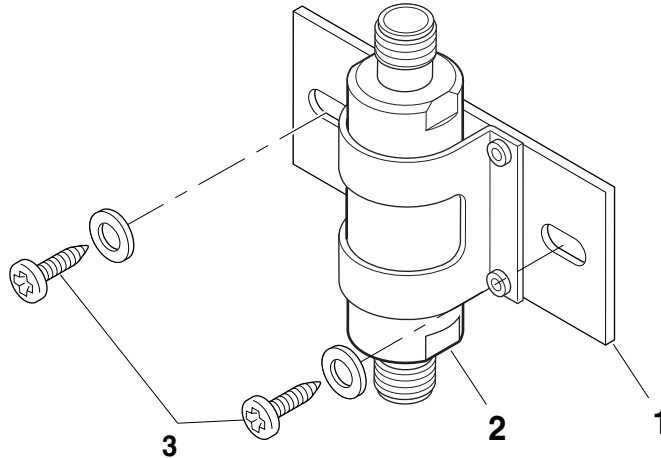

**Figure 6. Surface Mounting the Line Amplifier**

- **Required Parts:**

- Mounting plate, brace, and 4 screws (Option AUB or ordered separately).
- Anchors and fasteners for masonry surfaces (customer-supplied).
- Wood screws for wood surfaces (customer-supplied).

**Note:** Protecting outdoor connections is recommended. Refer to Section 8.0 for more information.

## 8.0 Environmental Considerations

It is recommended that all cable connections that are outdoors or exposed to wet or humid environments be sealed to prevent moisture from entering the connector. Shrink tubing is supplied with the line amplifier, but for maximum protection, a multi-barrier process is suggested. Both procedures are described here.

### ***A Multi-Barrier Process***

A multi-barrier process provides maximum protection for connections. An example of this process might consist of the following steps:

1. Wrap the connection with a self-fusing, insulating tape (for example, 3M Scotch™ 23 Rubber Splicing Tape).
2. Overwrap the self-fusing tape with a layer of vinyl electrical tape (for example, 3M Scotch™ Super 88 Vinyl Electrical Tape).
3. Cover with a layer of oil and water resistant coating (for example, 3M Scotchkote™ Electrical Coating).

**Note:** For specifics, please refer to the manufacturer's instructions.

### ***Weatherproofing an Amplifier with Shrink Tubing***

Although a multi-barrier process is suggested for weatherproofing (described above), shrink tubing can be used for a minimum level of protection. The following steps describe how to apply shrink tubing to an amplifier connector.

**Step 1.** Slip one of the pieces of the supplied shrink tubing over a cable, and connect the cable to the output connector of the amplifier.

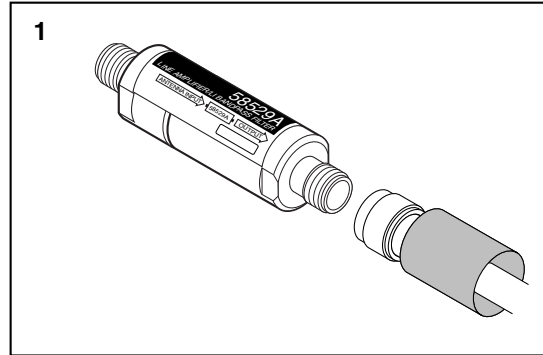

**Step 2.** Push or position the shrink tubing tightly against the case of the line amplifier. Using a heat gun or similar heat source, start heating the shrink tubing at the line amplifier input end, working toward the cable as shown.

**Caution:** Ensure that you do not overheat the amplifier. Do not point the heat source directly at the line amplifier for an extended period of time.

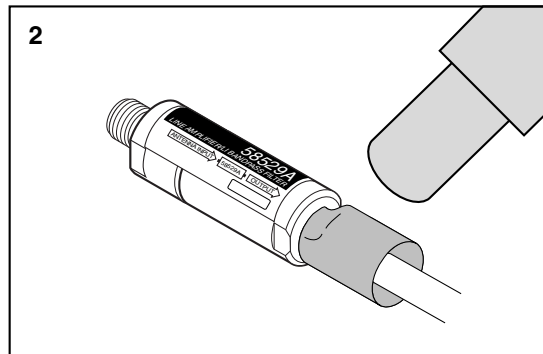

**Step 3.** When properly installed, the shrink tubing should cover the RF connector as shown.

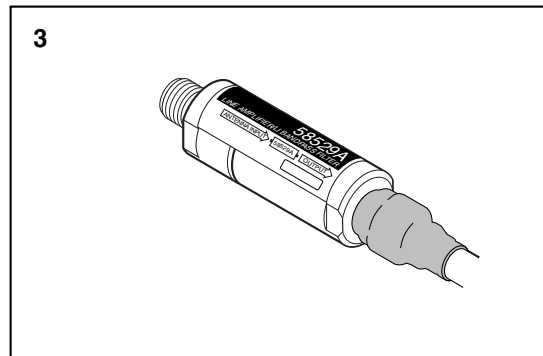

## 9.0 Maintenance

No periodic maintenance is required for the line amplifier. However, over time it is inevitable that exposure to weather will cause deterioration in the ability of the protected cable connections to resist moisture and weathering. It is recommended that all components of the antenna system that are exposed to weather be checked periodically and replaced, if necessary, as specified in your company procedures.

## 10.0 Specifications/Characteristics

The following table presents the specifications for the 58529A Line Amplifier with L1 Bandpass Filter.

**Table 1. 58529A Specifications/Characteristics**

Input/Output Impedance	50 $\Omega$
Amplifier Gain	> 20 dB (25 dB typical) in the passband
Filter Attenuation	> 15 dB @ 1575.42 MHz (L1) $\pm$ 75 MHz > 30 dB @ L1 $\pm$ 140 MHz
Reverse Isolation (output to input)	> 40 dB (typical)
Noise Figure	< 4.3 dB (3.8 dB typical)
VSWR	Input: 1.4:1 (typical) Output: 1.7:1 (typical)
RF Input Level (antenna signal) Maximum operating level	-25 dBm
DC Power Operating voltage Operating current	+4.5 Vdc to +13 Vdc < 13 mA
Connectors	2 Type-N Jacks
Operating Environment	-40°C to +80°C
Weight	440 g
Dimensions (including connectors)	31.5 mm D x 108.3 mm L